



# Woltex M

## Horizontal Woltmann meter with extended accuracy range for water distribution applications

- ▶ Hermetically sealed register (copper can/mineral glass envelope)
- ▶ Extended range approval
- ▶ Interchangeable approved mechanisms without re-calibration
- ▶ Pre-equipped through Cyble as a standard



Woltex M is a horizontal Woltmann meter available in sizes from DN 50 to 500. With its extended accuracy range it is dedicated to all applications around water distribution where high reliability and accuracy is requested.

### Extended Approved Range

Variable Qn EEC/ISO approval of Woltex M ensures an unmatched approved range of 107:1 (from Qmin to Qmax) instead of 66:1 for standard class B meters. This is ensuring accurate and reliable data collection in a large scope of flow-rates typical of water network applications. Leakage detection as far as peak demands are accurately monitored initially and over time.

### Endurance & Peak Flow Resistance

This extended approval is the result of more than twenty years experience in

Horizontal Woltmann design, from the first hydrodynamically balanced helix patent in 1985 still resulting in unmatched endurance capabilities to the use of high quality materials.

### Ease of Installation, Read and Maintenance

Woltex M range is available in various lengths and connections to minimize installation costs. Interchangeable approved mechanisms allows easy maintenance without re-calibration. Ease of read in the toughest environments (ie: flooded pits) is secured by orientable hermetically sealed register (copper can/mineral glass envelope).

### Communication Device

Pre-equipped for future communication through Cyble.

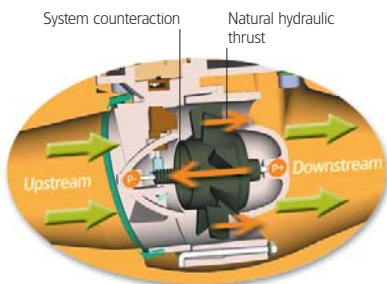

► Hydrodynamic balance of helix



► Woltex M indicator



► Cyble RF fitted on Woltex M with specific lid

## Working Principle

The water velocity is rotating the horizontal axis propeller. Special shape of its inlet and outlet bearing **1** is counteracting the natural hydraulic thrust applied on the propeller then preventing any downstream pivot wear.

This hydrodynamic balance was firstly patented on Woltex range in 1985 and still features Woltex with unmatched enduring capacities. This results in a meter able to withstand sustained high flows without impacting low flow accuracy. This allows Woltex to be approved according the provisions of EEC/ISO with variable Qn extended range.

The propeller rotation is transmitted by a protected transmission and direct magnetic coupling **2** to the register.

The cast iron body **3** is durably protected against the effects of corrosion by epoxy powder coating.

The hermetically sealed copper can/mineral glass register **4** is safeguarding the read and integrity of the indicator in the toughest environments (flooded pits, mechanical tampering attempts, ...).

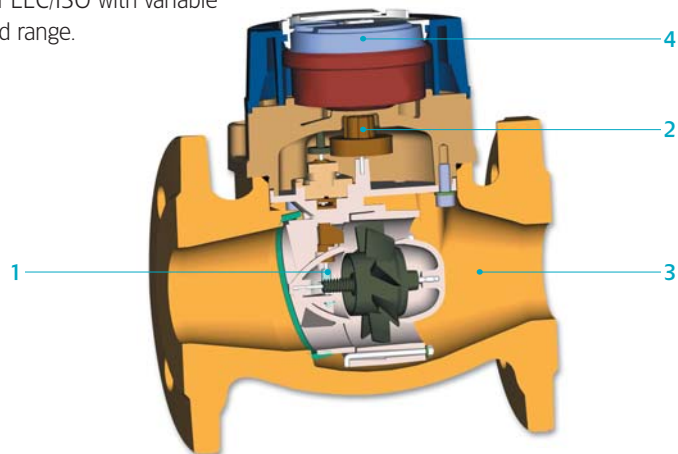

## Communication

**Woltex M is supplied pre-equipped with Cyble Target**

Allows communication and remote reading through:

- Pulse output (Cyble Sensor)
- M-Bus protocol (Cyble M-Bus)
- Radio frequency wireless link (Cyble RF)

These Cyble modules allow the Woltex M meter to be connected with various associated systems if and when desired. They are particularly adapted to commercial and industrial applications where a need for frequent meter monitoring is expressed especially in hard-to-read locations.

## Variable Qn Approved Range

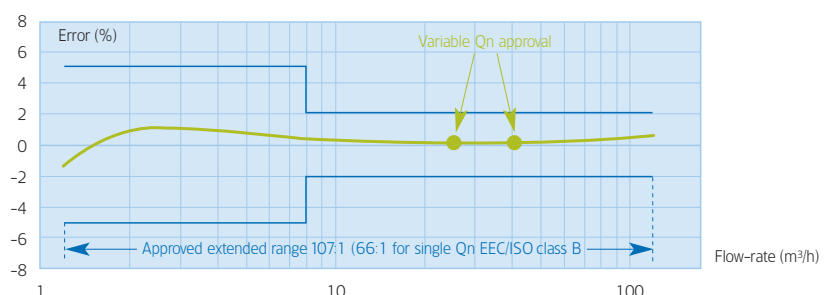

## Metrological Characteristics

### Typical Performance

Nominal diameter (DN)	mm	50	65	80	100	125	150	200	250	300	400	500	
	inches	2"	2" 1/2	3"	4"	5"	6"	8"	10"	12"	16"	20"	
Starting flow rate*	m <sup>3</sup> /h	0.19	0.22	0.3	0.38	0.4	1	1.6	3	10	15	20	
Accuracy ± 2% from*	m <sup>3</sup> /h	0.4	0.6	1.2	1.5	1.5	3	3.5	5	15	30	40	
Accuracy ± 5% from*	m <sup>3</sup> /h	0.35	0.5	0.75	0.9	1.2	1.5	2.5	3.5	12	25	30	
Admissible peak flow (10' max.)	m <sup>3</sup> /h	90	200	250	300	300	700	1 000	1 500	2 500	4 500	7 000	
Max. admissible flow rate (continuous)	m <sup>3</sup> /h	50	80	120	200	200	500	800	1 200	2 000	3 000	5 000	
Head loss at Qmax	bar	0.2	0.5	0.55	0.23	0.23	0.15	0.12	0.12	0.2	0.17	0.3	
Max. admissible temperature	°C	50											
Max. admissible pressure	bar	20											
Min. scale interval	L	0.5					5					50	
Indicating range	m <sup>3</sup>	999999.99					9999999.9					99999999	
Cyble HF pulse weight	L	10					100					1 000	

\* Average values.

### EEC Approval Values

Nominal diameter (DN)	mm	50	65	80	100	125	150	200	250	300	400	500	
	inches	2"	2" 1/2	3"	4"	5"	6"	8"	10"	12"	16"	20"	
EEC/ISO class approval							Class B all positions						
Nominal flow rate Qn (variable)	m <sup>3</sup> /h	25	25	40	60	100*	150	250	400	600	1 000	1 500	
		15	40	60	100	-	250	400	600	1 000	1 500	2 500	
Max. flow rate Qmax	m <sup>3</sup> /h	50	80	120	200	200	500	800	1 200	2 000	3 000	5 000	
Accuracy ± 2% class B: Qt from	m <sup>3</sup> /h	3	5	8	12	20	30	50	80	120	200	300	
Accuracy ± 5% class B: Qmin from	m <sup>3</sup> /h	0.45	0.75	1.2	1.8	3	4.5	7.5	12	18	30	45	
Max. working pressure	bar	20											
Max. temperature	°C	30											
EEC approval certificate		F-02-G071											

\* DN 125 single Qn approval only.

## Head Loss

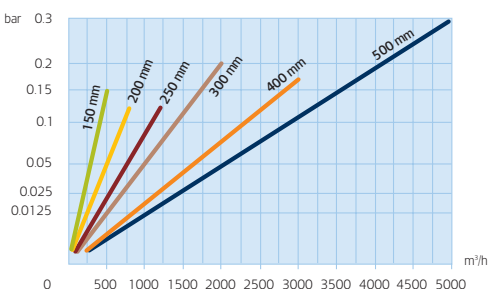
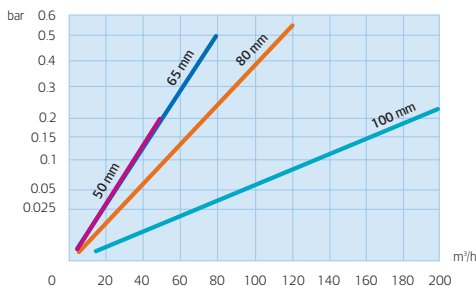

## Variants and Options

- ▶ Hot water up to 130°C – high pressure PN40 versions available on request.
- ▶ Wire sealed metallic cap equipped with a lockable lid is available as an option for harsh environments.



## Dimensions

Nominal diameter (DN)	mm	50	65	80	100	125	150	200	250	300	400	500	
	inches	2"	2" 1/2	3"	4"	5"	6"	8"	10"	12"	16"	20"	
End connection		Flange PN 10/16						Flange PN 10 or 16					
<b>• Meter</b>													
A (length)	ISO	mm	200	200	200	250	250	300	350	450	500	600	800
	DIN	mm	200	200	225	250	-	300	350	-	-	-	-
	ISO long	mm	300	300	350	350	-	500	-	-	-	-	-
	AS (Australia/UK)	mm	311	-	413	-	-	-	-	-	-	-	-
B		mm	100	100	100	111	111	139	164	214	200	250	350
C		mm	100	100	100	139	139	161	186	236	300	350	450
D		mm	82.5	92.5	100	110	110	142.5	171	204	230	290	357.5
E		mm	160	160	160	169	169	194	220	195	342	342	342
F		mm	243	253	261	279	294	339	391	399	564	632	689
G		mm	165	185	200	220	220	285	340	405	460	580	715
H		mm	262	262	262	309	309	395	420	395	729	729	729
Weight		kg	11.4	12.6	14.1	19.5	19.5	34	55	75	175	255	390
<b>• Mechanism</b>													
L		mm	123	123	123	166	166	212	332	256	350	350	350
I (max. width)		mm	148	148	148	182	182	273	276	276	426	426	426
M		mm	160	160	160	169	241	194	195	195	342	342	342
Weight		kg	3	3	3	5.4	5.4	7.8	8.5	8.5	54	54	54

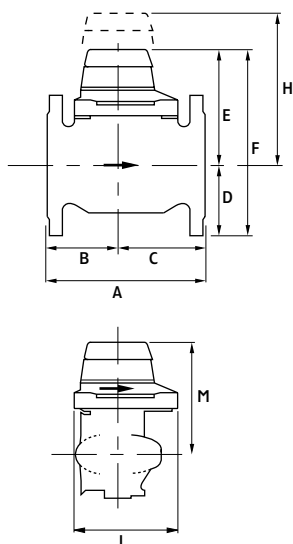

## Installation Requirements

- Woltex M could be installed regardless of position (EEC/ISO approval class B all positions).
- Installation of a strainer upstream of the meter is recommended to protect the hydraulics against raw particles (see Actaris strainer leaflet).
- We recommend the installation of a flow straightener directly upstream of the meter to cancel the effects of hydraulic perturbations on Horizontal Woltmann accuracy (see Actaris straightener leaflet).

Authorised Channel Partner in India

**Universal**  
*engineers*

BE-200, Lane No. 6,  
Hari Nagar, New Delhi -110064  
Tel./Fax : 91-11-25127461, 25496072, 9958004710  
GSM: 9810269366, 9810589043  
E-mail: [dynamic6@vsnl.com](mailto:dynamic6@vsnl.com), [contact@ues.net.in](mailto:contact@ues.net.in)  
[www.ues.net.in](http://www.ues.net.in)