

RUBIN

Cold water

Applications

RUBIN cold water meters operate according to the flowrate measuring principle using a Woltmann turbine and are designed for high-volume water measurement. The complete modular system covers a wide measuring range in all areas of water supply management.



Features

- High overload capacity
- Symmetrical control for high accuracy in both directions (optional)
- Register unit to IP 68 (protected against continuous immersion)
- The hydrodynamic counter-pressure generated by the special geometry of the WPKD helps to ensure a floating, low-friction turbine bearing

Your benefits

- The register unit can be rotated through 360° to provide the best reading position
- Optional local and/or remote display
- The hermetically encapsulated roller counter can be retrofitted with up to 3 pulsers without destroying seals
- The measuring units can be removed and certified

Parts and materials

RUBIN WPKD

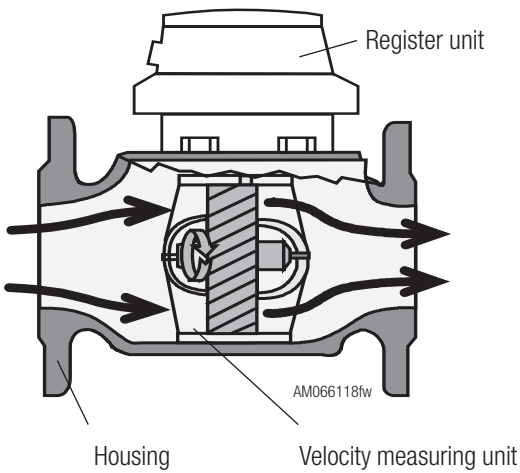

Part	Material
Housing assembly	
Housing	GG 25
Velocity measuring unit screws	stainless steel
Velocity measuring unit assembly	
Complete turbine	
Turbine	PP (< DN 65) PPS (> DN 80)
Cap jewel	sapphire
Bearing bushing for turbine	PPS
Complete regulating device	
Regulating ring	PPS
Push rod	stainless steel
Regulating bolt	brass
O-ring for regulating bolt	EPDM
Locking screw	brass
Complete velocity measuring unit body	
Head seal	EPDM
Cover flange	tinned brass
Basic body of unit	PPS
Moulded seal	EPDM
Protecting tube	PPS
Bearing ring	stainless steel
Bearing bushing for transmission shaft	PPS
Transmission shaft	PPS/stainless steel
Gear wheel for transmission shaft	PPS
Magnetic coupling	PPS/hard ferrite
Water flow stabiliser	PPS
Bearing bolt	stainless steel
Baffle plate	PPS
Register unit assembly	
Circular gasket, lip seal	EPDM
Filler plug, centring ring, conversion ring	PPO
Sealing plate	brass
Sealing plug	PPS
Sliding ring	PC
Mechanism	glass/copper
Nameplate	PV film
Cover	POM

Explanation of abbreviations

GG	Grey cast iron
PPS	Polyphenylene sulphide
PPO	Polyphenylene oxide
POM	Polymethylene oxide
PA	Polyamide
PC	Polycarbonate
EPDM	Ethylene/propylene
PV	Plyvinyl

RUBIN WSDK

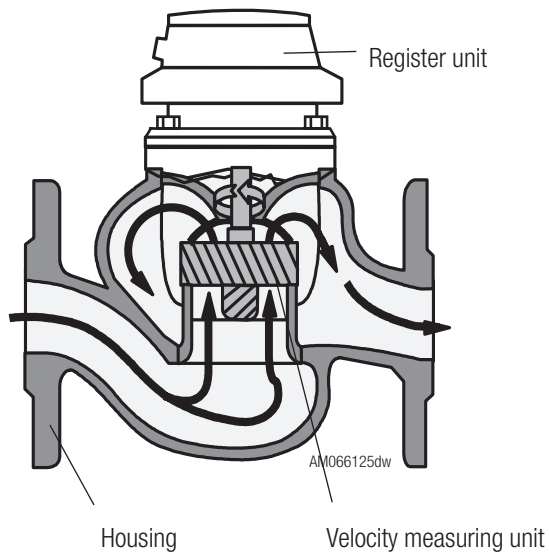

Explanation of abbreviations

GG	Grey cast iron
PPS	Polyphenylene sulphide
PPO	Polyphenylene oxide
POM	Polymethylene oxide
PC	Polycarbonate
EPDM	Ethylene/propylene
PV	Polyvinyl

Part	Material
Housing assembly	
Housing	GG 25
Velocity measuring unit screws	stainless steel
Velocity measuring unit assembly	
Complete turbine	
Turbine / turbine shaft	PPS
Pin	hard metal
Washer, bushing	stainless steel
Bearing plate and locating ring	sapphire
Bearing sleeve, clip	brass
Magnet	hard ferrite
Complete regulating device	
Regulating vane	PPS
Push rod, threaded pin, bolts	stainless steel
O-ring	EPDM
Complete velocity measuring unit body	
Base pin, washer, hexagonal nut	stainless steel
Pin	hard metal
Upper section of unit	PPS
Lower section of unit	PPS
Bushing	stainless steel
Register unit assembly	
Circular gasket, lip seal	EPDM
Filler plug, centring ring, conversion ring	PPO
Sealing plate	brass
Sealing plug	PPS
Sliding ring	PC
Mechanism	glass/copper
Nameplate	PV film
Cover	POM

Range

RUBIN WPKD



- Woltman turbine meters with dry-type registers, IP68
- Low pressure loss
- Better than Metrological Class B
- Error tolerances: $\pm 2\%$ of flow rate in the upper measuring range, $Q_t \leq Q \leq Q_{max}$, and $\pm 5\%$ in the lower measuring range, $Q_{min} \leq Q < Q_t$
- The meter can be installed in horizontal, vertical oder inclined positions. The meter head must however face upwards or to the side. The inlet and outlet straight pipe sections should be 3 x DN and 2 x DN, respectively.
- Powder-coated grey cast iron housing with flange connections
- Nominal pressure: PN 16 ¹⁾
- Maximum temperature: 50°C ²⁾
- Pressure loss: <0.25 bar at Q_n according to factory specification

Nominal diameter	DN	mm Inches	40	50	65	80	100	125	150	200	250 ⁵⁾	300 ^{5) 6)}
			1 1/2	2	2 1/2	3	4	5	6	8	10	12
Article No.			92419	92421	92422	92423	92424	92425	92426	92427	180535	180535
Maximum flowrate	Q _{max} ³⁾	m ³ /h	60	90	120	200	300	350	600	1200	1600	2000
Nominal flowrate	Q_n	m³/h	40	50	70	120	230	250	450	800	1250	1400
Transitional flowrate	Q _t	m ³ /h	0.8	0.7	0.8	0.8	1.8	2	4	6	11	15
Minimum flowrate	Q _{min}	m ³ /h	0.3	0.3	0.4	0.5	0.8	1.0	1.8	4	6	12
Starting flow at approx.		m ³ /h	0.15	0.15	0.20	0.25	0.25	0.50	1.0	1.5	3	8
According to EEC type approval class B ⁴⁾												
Maximum flowrate	Q _{max} ³⁾	m ³ /h	30	30	50	80	120	200	300	500	800	1200
Nominal flowrate	Q_n	m³/h	15	15	25	40	60	100	150	250	400	600
Transitional flowrate	Q _t	m ³ /h	3	3	5	8	12	20	30	50	80	120
Minimum flowrate	Q _{min}	m ³ /h	0.45	0.45	0.75	1.20	1.80	3.00	4.5	7.5	12	18
Smallest readable volume		Litres	1	1	1	1	1	1	10	10	10	10
Recording capacity		Mio m ³	1	1	1	1	1	1	10	10	10	10
Body surface finish			blue coating									
Weight		approx. kg	7.5	8	10	15	18	21	36	51	73	100
	Overall length L		220	200	200	225	250	250	300	350	450	500
	h		96	73	85	95	105	118	135	162	194	226
	H		120	120	120	150	150	160	177	206	231	256
	g		200	200	200	270	270	280	356	441	466	491

- 1) PN 10 and PN 40 on request
- 2) Available up to 130°C (as WPDH hot water meters)
- 3) During a maximum total of 24 h
- 4) EEC type approval of model: D95 / 6.132.36, class B; the values shown are those taken from the official verifications
- 5) Supplied on request
- 6) Larger diameters available on request.

Pressure loss curves

(see page 10)

Type approval

SVGW

DN 50...300

8407-1530

(WPKD 50...300)

RUBIN WSDK



- Woltman turbine meters with dry-type registers, IP68
- Better than Metrological Class B
- Error tolerances: $\pm 2\%$ of flow rate in the upper measuring range, $Q_t \leq Q \leq Q_{max}$, and $\pm 5\%$ in the lower measuring range, $Q_{min} \leq Q < Q_t$
- For installation in horizontal pipes, so that the dial is horizontal and facing upwards; the inlet section should be $3 \times DN$ and the outlet section $2 \times DN$.
- Powder-coated grey cast iron housing with flange connections
- Nominal pressure: PN 16 ¹⁾
- Maximum temperature: 50°C ²⁾
- Pressure loss: < 0.25 bar at Q_n according to factory specification

Nominal diameter	DN	mm	50	65	80	100	150
		inches	2	2 1/2	3	4	6
Articel No.			92349	92356	92357	92358	92359
Maximum flowrate	Q_{max} ³⁾	m ³ /h	35	70	110	180	350
Nominal flowrate	Q_n	m³/h	20	40	55	90	250
Transitional flowrate	Q_t	m ³ /h	1	2.5	2.5	3	5
Minimum flowrate	Q_{min}	m ³ /h	0.15	0.20	0.20	0.30	0.80
Starting flow at approx.	m ³ /h		0.07	0.10	0.11	0.50	
According to EEC type approval class B ⁴⁾							
Maximum flowrate	Q_{max} ³⁾	m ³ /h	30	50	80	120	300
Nominal flowrate	Q_n	m³/h	15	25	40	60	150
Transitional flowrate	Q_t	m ³ /h	4.5	5	8	12	30
Minimum flowrate	Q_{min}	m ³ /h	0.45	0.75	1.20	1.80	4.50
Smallest readable volume		litres	1	1	1	1	10
Recording capacity		Mio m ³	1	1	1	1	10
Body surface finish	blue coating						
Weight		approx. kg	12.5	16.5	18.5	31.5	89.5
	Overall length	L	270	300	300	360	500
		h	80	100	100	110	180
		H	151	161	161	191	301
		g	281	301	301	341	581

1) PN 10 and PN 40 on request

2) Available up to 130°C (as WSDH hot water meters)

3) During a maximum total of 24 h

4) EEC type approval of model: D95 / 6.132.36, class B; the values shown are those taken from the official verifications

Pressure loss curves

(see page 10)

Type approval

SVGW

DN 50...150

8407-1529

(WSDK 50...150)

Roller counters

WPKD 50...125 and WSDK 50...100

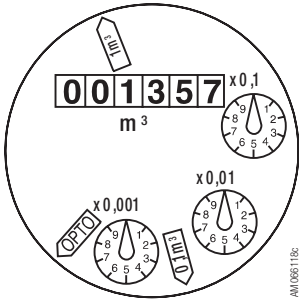

WPKD 150...300 and WSDK 150

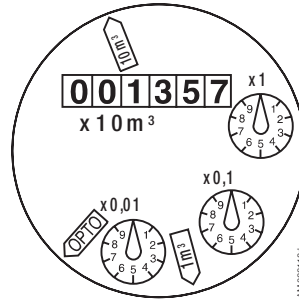

Pulsers

WPKD and WSDK

The Reed and optoelectric pulsers can be retrofitted without destroying the seals. The Reed DS 01 pulser can be installed in two positions with different pulse values as indicated on the dial. Smaller pulse values are to be stated when ordering special versions of the RD (on request).

Reed pulsers RD 01 and RD 011

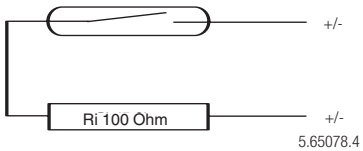
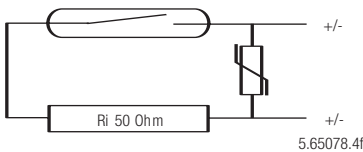

Switch type	• Reed contact tube protected with an inert gas filling; plug-in design
Contact protection	• RD 01: with protective resistor (50 Ω) and varistor • RD 011: with protective resistor (100 Ω) • RD 011: mit Schutzwiderstand 100 Ω
Switch voltage	• RD 01: max. 48 VAC or DC • RD 011: max. 125 VAC or DC
Switch current	• RD 01: max. 200 mA • RD 011: max. 35 mA
Quiescent current	• Contact open
Contact rating	• RD 01: max. 4 W • RD 011: max. 2 W
Ambient temperature	• -10 ... +70°C
Protection class	• IP 68 according to IEC 144
Connection	• Fixed mounting cable, length: 3 m
Article No. RD 01	• 93746
Article No. RD 011	• 93747

Optoelectronic pulsers OD 01 and OD 03

Switch type	• IR reflex light barrier to DIN 19234; plug-in design
Switch voltage	• 8.2 VDC
Switch current	• < 1.2 mA
Quiescent current	• > 2.1 mA
Forward/reverse flow recognition	• This is integrated by means of an additional current threshold at 1.5 mA
Ambient temperature	• -10 ... +70°C
Protection class	• IP 68 according to IEC 144
Connection	• Fixed mounting cable, length: 3 m
Article No. OD 01	• 93750
Article No. OD 03	• 93752

Nominal diameter	DN	mm	40	50	65	80	100	125	150	200	250	300
		Inches	1 1/2	2	2 1/2	3	4	5	6	8	10	12
Pulse values WPKD and WSDK												
RD 01/11 Reed (standard)		l/pulse	100	100	100	100	100	100	1000	1000	1000	1000
		l/pulse	1000	1000	1000	1000	1000	1000	10'000	10'000	10'000	10'000
RD 01/11 Reed (special version) ¹⁾		l/pulse	10	10	10	10	10	10	100	100	100	100
		l/pulse	1000	1000	1000	1000	1000	1000	10'000	10'000	10'000	10'000
OD 01 optoelectronic		l/pulse	1	1	1	1	1	1	10	10	10	10
OD 03 optoelectronic		l/pulse	10	10	10	10	10	10	100	100	100	100
Pulse frequencies WPKD												
OD 01 optoelectronic	at Qn ²⁾	Hz	11.11	13.89	19.44	33.33	63.89	69.44	12.50	22.22	34.72	38.89
	at Qmin	Hz	0.083	0.083	0.111	0.139	0.222	0.278	0.050	0.111	0.167	0.333
Pulse frequencies WSDK												
OD 01 optoelectronic	at Qn ²⁾	Hz	–	9.722	19.44	30.56	50.00	–	9.72	–	–	–
	at Qmin	Hz	–	0.041	0.055	0.055	0.083	–	0.222	–	–	–

1) Requires special version counter, to be stated when ordering.

2) Qn as stated in the factory specification

Installation notes

Nominal sizes: pipes, meters and pipe reducers

The choice of the nominal meter size should not automatically be based on the nominal size of the pipe. The decisive factor is the highest flowrate that occurs continuously in the pipe - this determines the nominal flowrate Q_n of the meter.

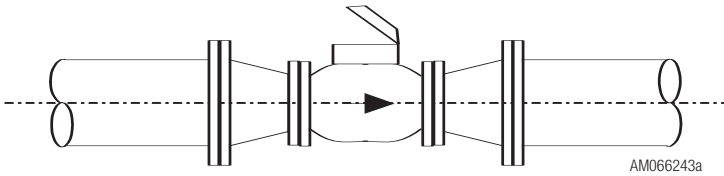

Pipe bends and flow straighteners

The flow profile is modified by the pipe bend or pipe reducers to such an extent that it alters the incoming flow to the meter turbine. As a result, measuring accuracy is impaired which can be prevented by suitable structural precautions. For these purposes, flow straighteners which regularize the profile can be used, these being installed directly downstream of the pipe bend. If there is enough space, additional "smoothing" sections should be added. Flow straighteners also exist in combination with pipe reducers.

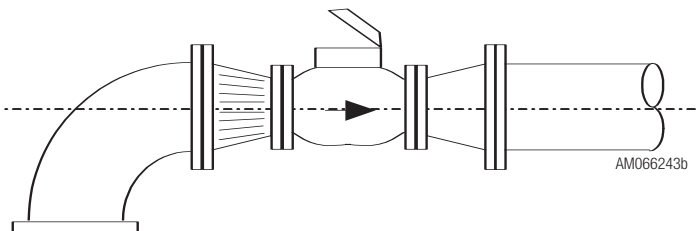

Inlet and outlet sections

Woltman meters attain maximum accuracy if adequate inlet and outlet sections are included in the design of the measuring point. The inlet section should be at least $3 \times DN$ or a flow straightener should otherwise be installed. The requirements for the outlet section are less strict since the only essential requirement is to avoid abrupt changes of cross-section directly after the meter.

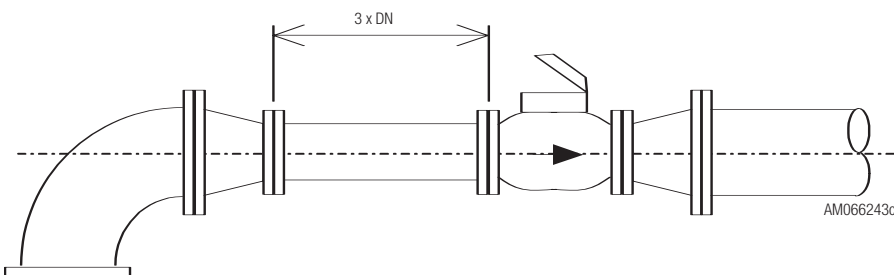

Mounting height

RUBIN Woltman meters have exchangeable velocity measuring units which can be tested and calibrated independently of the housing. For this purpose, the old units are removed upwards. When designing the installation, it is important to ensure that there is adequate space above the meter for removal.

Installation position / vertical pipes

Note: with vertical pipes, you must always use a RUBIN Woltman meter of type WPDK (but if a WSDH has to be fitted specific to the installation, we would remind you that the metrological approval requirements will not be satisfied with the meter installed in this position). Meters must not be installed upside-down as then the metrological approval requirements will not be met.

Electrical installation

Electrical cables and installation must be carried out by a specialist in accordance with legal requirements.

Measurement error limits

According to Directive 75/33/EEC and ISO 4064-1

Reference conditions: Medium = water, temperature = 20 °C

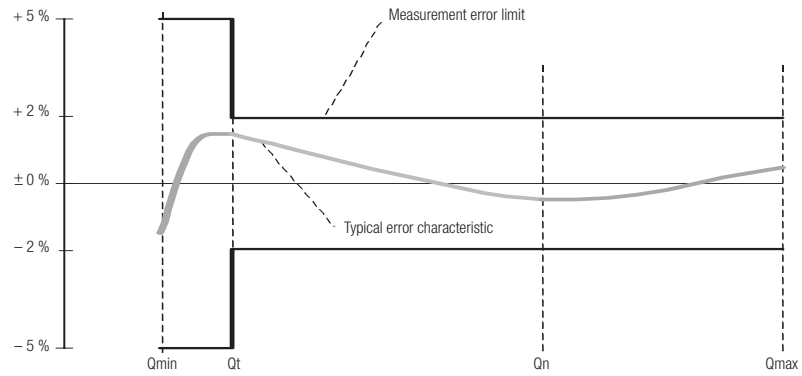

$Q_{min} \leq Q < Q_t$

lower load range

$Q_t \leq Q \leq Q_{max}$

upper load range

Pressure loss curves

RUBIN WPKD

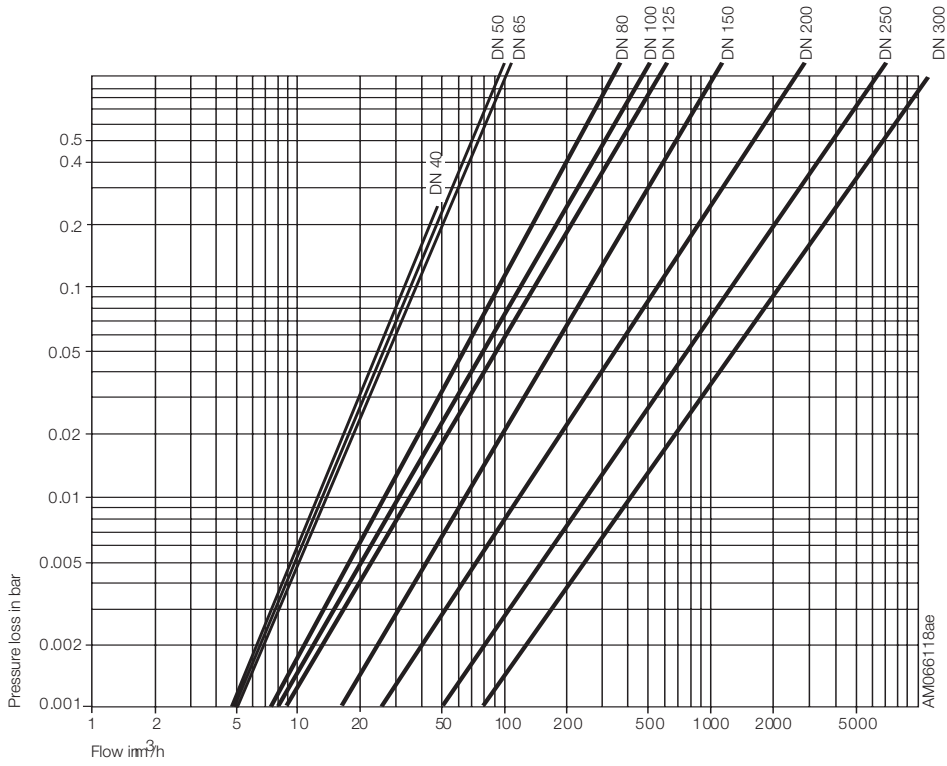

RUBIN WSDK

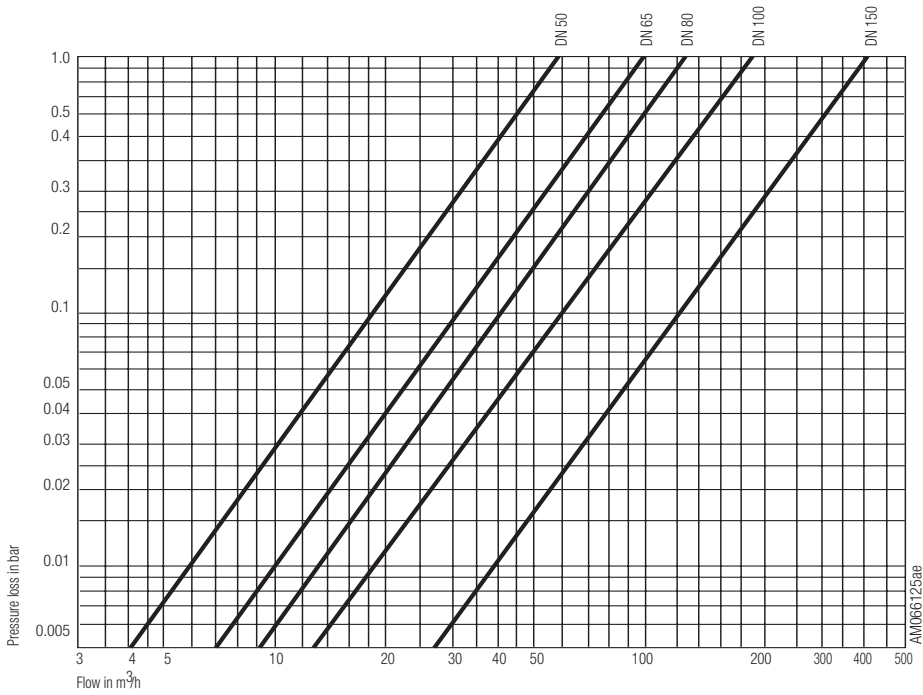

Authorised Channel Partner in India

Universal
engineers

BE-200, Lane No. 6,

Hari Nagar, New Delhi -110064

Tel./Fax : 91-11-25127461, 25496072, 9958004710

GSM: 9810269366, 9810589043

E-mail: dynamic6@vsnl.com, contact@ues.net.in

www.ues.net.in

