

# Radial-Blade Turbine Gas Meter TRZ

for obligatory verification



## Technical characteristics Radial-Blade Turbine Gas Meter TRZ

- Principle of velocity measurement
- For measurements requiring obligatory verification
- Sizes G 16 up to G 400
- Dimensions DN 50, 80 and 100
- Different G-sizes per nominal width:
  - DN 50: G 16 up to G 100
  - DN 80: G 65 up to G 250
  - DN 100: G 160 up to G 400
- Operating pressure max. 6 bar
- Meter element can be calibrated without monopipe fitting
- Pressure extraction connection inside the meter
- Counting device is in a gas-free space
- Low starting value
- High measurement stability and operational security due to high-quality, wear-resistant components; self-lubricating ball bearings
- Designed for simple servicing (measurement-cartridge principle)
- LF-pulse generator (standard)

- Standard integrated flow strainer
- Short straight inlet lengths (2 × DN)
- Operation temperature range:
  - gas temperature –10°C up to +60°C
  - ambient temperature –20°C up to +70°C

## Options

- Over-run brake: Mechanical over-run brake without measuring range for intermitting operation
- Pulse generator:
  - 2nd LF-IPG, can be retrofitted without breaking the verification seal
  - MF-IPG
  - HF-IPG
- Temperature sensor pockets in monopipe fitting

## Mounting and maintenance

- Mounting/dismounting of the meter element possible without disconnecting the monopipe fitting
- The monopipe fitting remaining in the pipe network enables mounting/dismounting of the meter element without tension from the pipe network
- Can be installed in any position from horizontal to vertical (turbine axis not suspended and roller counter axle always horizontal)

## Norms and approvals

- Developed and produced according to Quality Standard ISO 9001
- International and national type approvals



## Technical Data Radial-Blade Turbine Gas Meter TRZ

DN (mm)	Sizes	Load range		Operating pressure $p_{max}$ (bar)	Pulse generators			
		$Q_{min}$ (m <sup>3</sup> /h)	$Q_{max}$ (m <sup>3</sup> /h)		LF (standard) 1 pulse = m <sup>3</sup>	2nd LF (option) 1 pulse = m <sup>3</sup>	MF (option) 1 pulse = m <sup>3</sup>	HF (option) approx. f at $Q_{max}$ (Hz)
50	G 16	5	25	6	1	1	0,01	350
50	G 25	4	40	6	1	1	0,01	550
50	G 40	6	65	6	1	1	0,01	850
50	G 65	5	100	6	1	1	0,01	1300
50	G 100	8	160	6	1	1	0,01	1300
80	G 65	10	100	6	1	1	0,01	200
80	G 100	16	160	6	1	1	0,01	320
80	G 160	13	250	6	1	1	0,01	500
80	G 250	13	400	6	1	1	0,01	800
100	G 160	13	250	6	1	1	0,01	440
100	G 250	20	400	6	1	1	0,01	380
100	G 400	20	650	6	1	1	0,01	610

### Over-run brake

Radial-Blade Turbine Gas Meter without over-run brake NLB



Radial-Blade Turbine Gas Meter with over-run brake NLB



### Pulse generators

Connection of LF-, MF- as well as HF-pulse generators



LF-pulse generator can be fitted by user without breaking the verification seal



### Error curve

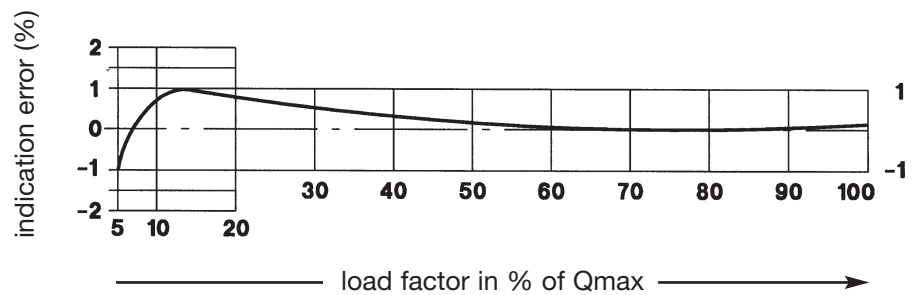

## Dimensional drawings

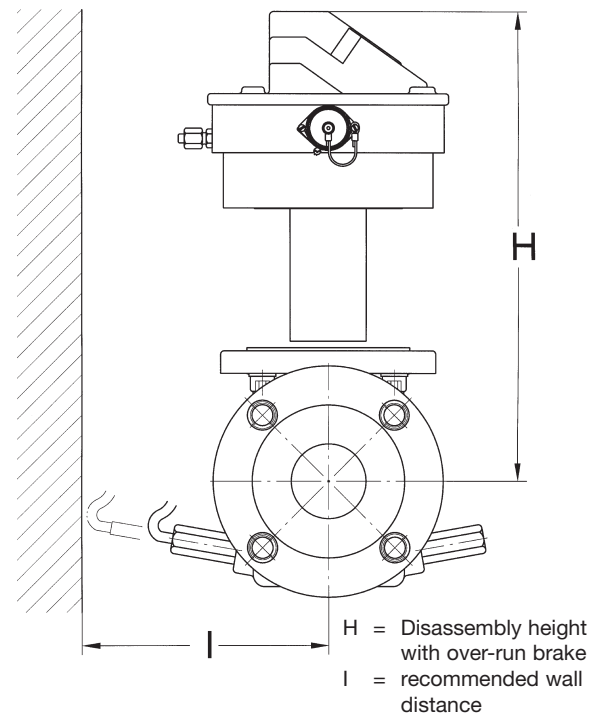
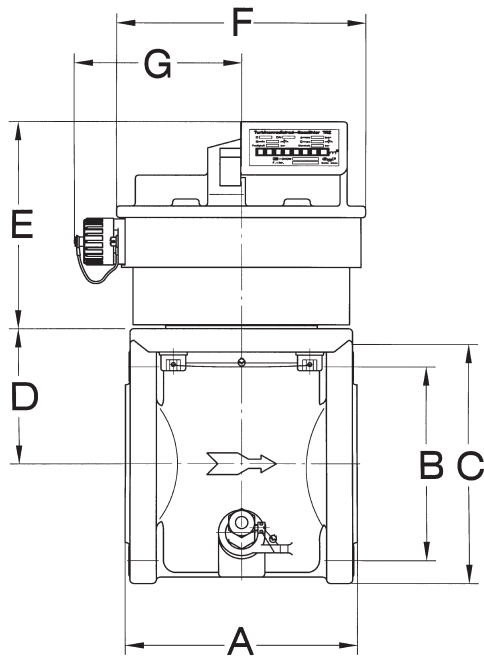

## Dimensions and weights monopipe fitting and gas meter TRZ

Monopipe fitting EAS				Dimensions (mm)									Weight (kg)	
Art. No.	Pipe connection	For meter	Thread (G) Flange (F)	A	B	C	D	E	F	G	H	I	Meter element	EAS
89.500014	G 2" *	DN 50	PN 4 - G	185	-	-	70	136	161	109	-	150	3,3	3,1
82.50039	G 2"	DN 50	PN 4 - G	185	-	-	87	134	161	109	332	150	3,3	5,8
82.5036	DN 50	DN 50	PN 16 - F 4-hole	150	125	165	87	134	161	109	332	150	3,3	10
89.5038	DN 65	DN 50	PN 16 - F 4-hole	340	145	185	87	134	161	109	332	150	3,3	13
89.5039	DN 80	DN 50	PN 16 - F 8-hole	380	160	200	87	134	161	109	332	150	3,3	16
82.8036	DN 80	DN 80	PN 16 - F 8-hole	240	160	200	120	150	190	115	423	200	5,9	16
82.0036	DN 100	DN 100	PN 16 - F 8-hole	300	180	220	130	170	220	125	460	200	9,1	24,2
EAS with 2 integrated pockets for temperature sensors				Dimensions (mm)									Weight (kg)	
82.5029	G 2"	DN 50	PN 4 - G	185	-	-	87	134	161	109	332	200	3,3	6
82.5037	DN 50	DN 50	PN 16 - F 4-hole	150	125	165	87	134	161	109	332	200	3,3	10,2
82.8037	DN 80	DN 80	PN 16 - F 8-hole	240	160	200	120	150	190	115	423	250	5,9	16,2
82.0037	DN 100	DN 100	PN 16 - F 8-hole	300	180	220	130	170	220	125	460	250	9,1	24,4

\* Only for meters without over-run brake

## Pressure loss gas meter DN 50

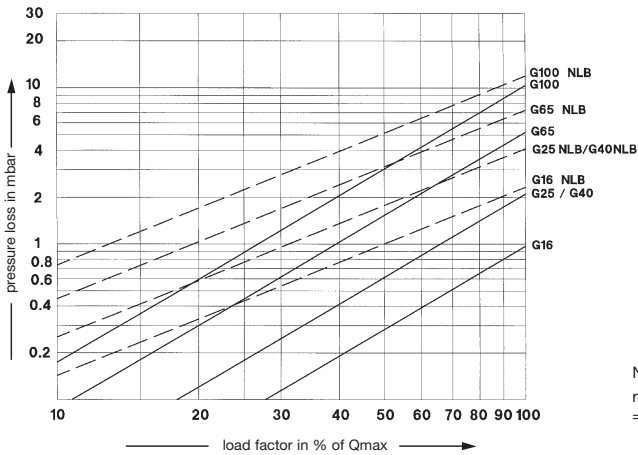

NLB = over-run brake  
reference density natural gas  $\rho$   
= 0,83 kg/m<sup>3</sup> (average value)

## Pressure loss gas meter DN 80

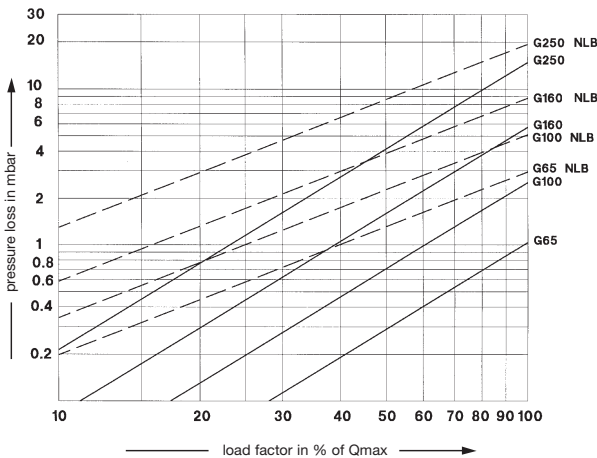

NLB = over-run brake  
reference density natural gas  $\rho$   
= 0,83 kg/m<sup>3</sup> (average value)

## Pressure loss gas meter DN 100

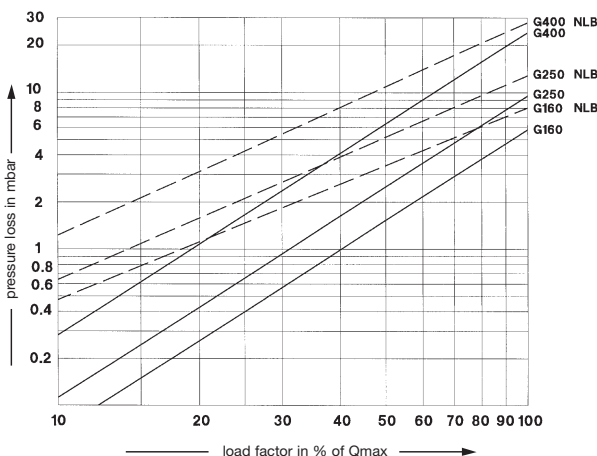

NLB = over-run brake  
reference density natural gas  $\rho$   
= 0,83 kg/m<sup>3</sup> (average value)

## Application example

### Direct mounting of volume correctors onto TRZ – advantages:

- The entire unit, meter with monopipe and volume corrector, can be delivered calibrated
- No additional welding for temperature sensor pockets and pressure connection
- No additional fastening devices required for mounting of volume corrector
- Low installation time and expenditure on-site
- Initiation on-site not necessary



Authorised Channel Partner in India

**Universal**  
*engineers*

BE-200, Lane No. 6,  
Hari Nagar, New Delhi -110064  
Tel./Fax : 91-11-25127461, 25496072, 9958004710  
GSM: 9810269366, 9810589043  
E-mail: [dynamic6@vsnl.com](mailto:dynamic6@vsnl.com), [contact@ues.net.in](mailto:contact@ues.net.in)  
[www.ues.net.in](http://www.ues.net.in)

**GWF**

The benchmark in metering technology