

for Tank Inventory, Pump Control and Open Channel Flow

Level & Flow Monitor

SLT32

For Chemical Tank Level
Sumps and Pump Stations
Flow through Flumes and Weirs

**with Non-Contacting
Ultrasonic Sensor**



SLT32 – Accurate, Simple and Reliable

Use it for Level

Specify SLT32 for inventory monitoring and level control of chemicals, wastewater, viscous or corrosive liquids. Built-in control relays are programmable for pump control, pump alternation and level alarms.

Use it for Flow

Displays, transmits and totalizes wastewater flow through any flume or weir. Features a simple, password protected calibration system, automatic totalizer and flow proportionate control relays.

No maintenance Sensor

Each SLT32 includes a non-contacting ultrasonic sensor which mounts above the material being measured. There is no contact and no moving parts. The sensor is sealed to withstand accidental submersion and rated for hazardous locations with optional intrinsic safety barrier.

RELIABLE MEASUREMENT AND CONTROL

Greyline SLT32 Level & Flow Monitor

Level

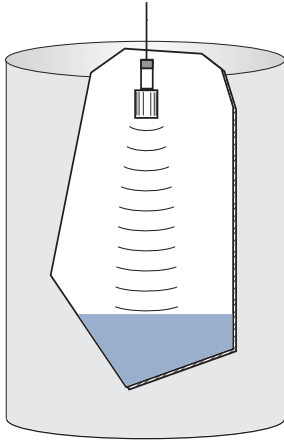

Tank Inventory and Pump Control

- Displays Continuous Level
- Controls Pumps and Alarms
- Transmits 4-20mA

Simple Installation and Calibration

Mount the SLT32 noncontacting ultrasonic sensor at the top of a tank to continuously monitor level. The Sensor self-tunes to extended cable lengths so the electronics enclosure/display can be mounted at a convenient location.

Select LEVEL or RANGE mode

It is fast and easy through the SLT32 calibration menu. Simply follow the menu prompts and set up the SLT32 to display level in your choice of measurement units (ft, cm, gallons, liters, percent etc.) for vertical and horizontal round tanks.



Advanced Operating System

You can control the SLT32's response to conditions like turbulence or splashing and to reject tank agitators. The SLT32 automatically adjusts itself to obtain the best signal. False echoes are suppressed and filtered to accurately display the correct level.

Pump Control and Alarms

Program separate ON and OFF set-points for the SLT32's 3 built-in control relays. Use them for pump control, pump alternation, high or low level alarms, air temperature alarms, automated valves or annunciators.

Isolated 4-20mA Output

Ready for direct connection to PLC's or computers and rated for 1000 ohm resistive load. Programmable offsets allow 4 and 20mA to be offset from the instrument calibration for special control applications.

Flow

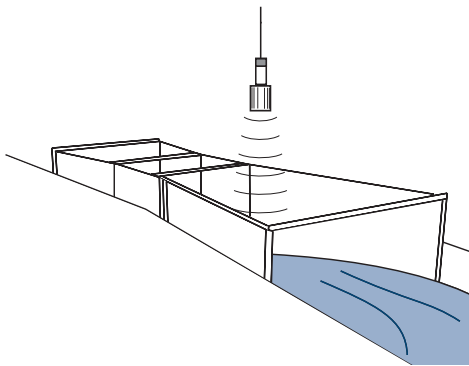

Open Channel Flow Monitoring

- Works with any Flume or Weir
- Built-in Totalizer
- Password protected Calibration

Select FLOW mode for Open Channel applications

Calibration is easy with Menu selection of common Flumes including Parshall, Palmer Bowlus and Leopold Lagco, and Weirs including V-Notch and Rectangular.

Displays, Totalizes, Transmits and Controls

The SLT32 large digital display shows the flow rate while the 16-digit display shows flow total. Use the SLT32 isolated 4-20mA output to transmit to chart recorders, and program the built in control relays for flow proportionate control (for samplers, chlorinators or external totalizers), and for flow/level alarms.



No Contact Sensor = No Maintenance

The SLT32 Sensor mounts over the flume or weir, so there is no sensor fouling or maintenance required. With built-in temperature compensation, the SLT32 maintains high accuracy (+0.25% of full scale) to meet environmental monitoring requirements.

Includes Free PC Software for Custom Calibration

Run this software on your PC to determine the calibration formula for custom flumes, weirs or open channels then enter the values into the SLT32 calibration menu.



SLT32 Specifications

General Specifications Greyline SLT32 Level & Flow Monitor

Electronics Enclosure:	Watertight and dust tight NEMA4X (IP 66) polycarbonate with clear, shatterproof cover
Accuracy:	±0.25% of Range or 2 mm (0.08") whichever is greater, Repeatability and Linearity: ±0.1%
Displays:	Numeric Values: large 4 digit LCD; Menu/Status/Totalizer: 16 digit alphanumeric
Operating Modes:	Level, Range or Open Channel Flow
Programming:	3-button keypad with Menu selection. Calibration parameters are Password protected
Power Input:	100-130VAC 50/60Hz, 6 watts maximum
Output:	Isolated 4-20mA, 1000 ohm load maximum, Programmable Offset
Control Relays:	3 Relays, form 'C' dry contacts rated 5 amp SPDT; programmable level alarm, pump control, pump alternation, failsafe/echo-loss, air temperature alarm
Electrical Surge Protection:	Sensor, 4-20mA and AC power input
Operating Temp. (electronics):	-5° to 140°F (-20° to 60°C)
Approximate Shipping Weight:	10 lbs. (4.5 kg)

Sensor Specifications

Maximum Range:	32 ft (10 m) with standard PZ32T sensor (Optional sensors for longer ranges)
Deadband (Blanking):	Programmable, Minimum 12 in (305 mm)
Beam Angle:	8°, Locate sensor 1 ft (300 mm) from tank sidewall for every 10 ft (3 m) depth
Operating Frequency:	42 KHz
Exposed Materials:	PVC and Teflon
Operating Temperature:	-40° to 150°F (-40° to 65°C)
Temperature Compensation:	Temperature probe inside level sensor for high accuracy in changing temperatures
Operating Pressure:	20 psi (1.35 bar) maximum
Sensor Cable:	RG62AU coaxial, 25 ft (7.6 m) standard length (See Options)

Options

Sensors:	Long range models / all Teflon construction / intrinsically safe / flange mount
Sensor Cable:	50 ft. (15 m) RG62AU coaxial continuous from Sensor, or splice up to 500 ft (150 m)
Sensor Cable Junction Box:	watertight NEMA4 steel with connection terminal strip
Power Input:	200-260VAC 50/60Hz, 12VDC (battery power) or 24VDC
Control Relays:	3 additional (6 total), rated 5 amp SPDT
Enclosure Heater:	Thermostatically controlled - recommended for temperatures below 32°F (0°C)
Data Logger:	Built-in, 50,000 data point capacity, with Windows™ software and RS232 output
Enclosure Panel Mount:	Flange assembly mounts standard enclosure
Sensor Mounting Stand:	For Open Channel Flow applications

Dimensions

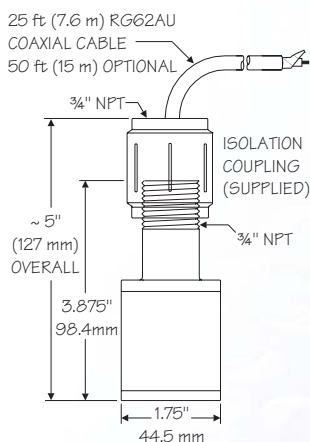

PZ32T SENSOR

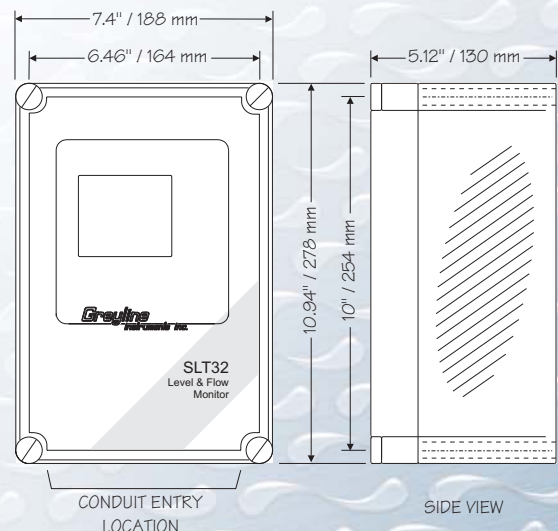

ENCLOSURE

User-Friendly SLT32 Level & Flow Monitor

Simple Installation and Fast, Easy Start-up



SIMPLE 3-KEY CALIBRATOR

PASSWORD: 00

Store? Yes

Temp 18.1°C

SIMUL 100.0%

Built-in 3-Key Calibrator – No Special Programming Codes

Scroll through the SLT32 set-up menu to control the instrument's operating features and calibration. Forget about Parameter codes and complex calculations! The SLT32 automatically calculates, converts and displays common engineering units (metric, English, US). Program it for tank level...horizontal round tank volume...range or tape measure mode...or open channel flow.

Use output simulation mode to take manual control of the SLT32 display, 4-20mA and control relays. You can test operation of equipment connected to the SLT32 and confirm correct calibration.

Use the SLT32 password feature to prevent unauthorized access to the calibration menu. An optional enclosure key-lock is also available.

Your calibration is written to the SLT32's memory (and permanently saved even through power interruptions). Change calibration or measurement units and Store again and the new data overwrites the previous.

Built-in temperature compensation automatically maintains the SLT32 accuracy throughout the full range of operating temperatures. Temperature at the sensor can be viewed on the SLT32 display.

The SLT32 self-tunes to extended sensor cable lengths up to 500 ft (152 m). The coaxial cable can be cut and spliced as required for your installation. Sensor cable or connection faults are automatically shown on the SLT32 display.

The standard sensor is constructed of PVC with a Teflon face and is designed to withstand accidental submersion without damage. Options include intrinsic safety for hazardous locations and all-Teflon construction for harsh or corrosive environments.

Authorized Channel Partner in India

Universal
engineers

BE-200, Lane No. 6,
Hari Nagar, New Delhi -110064
Tel./Fax : 91-11-25127461, 25496072, 9958004710
GSM: 9810269366, 9810589043
E-mail: dynamic6@vsnl.com, contact@ues.net.in
www.ues.net.in